

# Storage Cabinet Installations Manual

## Model-Laminate Top

Durable – Interchangeable - Easy to Install

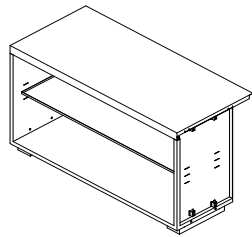
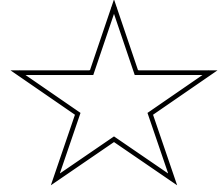
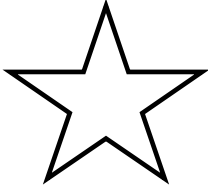

Cabinet - no doors  
Laminate Top

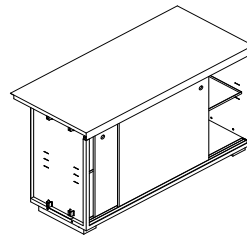

Cabinet - with doors  
Laminate Top

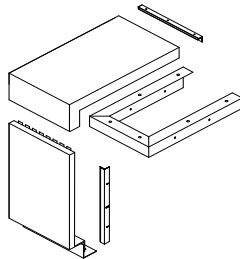

Filler Panel  
Laminate Top

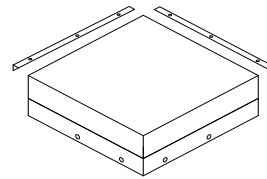

Corner section  
Laminate Top

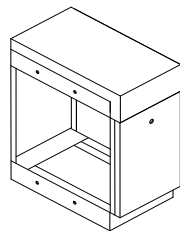

Utility Compartment

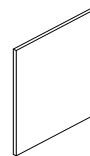

End Panel

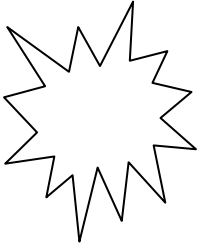

# Before you unpack this Equipment

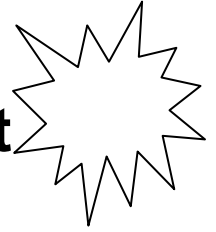

- Check for ALL carton for possible freight damages. If damaged, do not continue to open. Report all damages to the freight carrier and your sales representative.
- Count to make sure the number of boxes matches the packing slip. If they do not, check your Bill of Lading to make sure you received all your equipment.

## General Information

HVAC CUSTOM ENCLOSURE CO., LLC provides the industry with high quality cabinetry that is easy to install. Cabinets should be installed by a professional sheet metal contractor that is qualified in installing cabinetry to industry standards. Read your instruction manual prior to installing your equipment and familiarize yourself with the layout of the room, size, and arrangement of the cabinets. This manual will provide guide lines to install this equipment. Remember no two building are the same so some modification might be needed. Cabinets come with tops pre- assembled. Cabinets are available in two, three, four and five feet lengths. Each standard cabinet comes with one adjustable Shelve, Front Floor Skirts, Back Wall Brace, Back Channel and Hardware Pack. Fasteners required securing equipment to floors and walls *ARE SUPPLIED BY OTHERS*.

**NOTE:** *Additional fastening by others may be needed when Floors and Walls are not level or flat to align cabinets flush and square. Securing cabinets to Unit Ventilator may need additional fastening. (field supplied by others). If you cannot install cabinets level and flush-STOP & contact SHELVING REPRESENTATIVE.*

## Before Installing: (Additional tools and supplies may be needed)

You will need the following tools.

(Additional tools may needed for fastening to the wall and floor)

Adjustable Drill

Long Phillip Head Bit to fit in Drill (Magnetic Bit Recommended)

3/16" Allen Key

Tape Measure

Contractor Level

Marking Device

Rubber Mallet

Chalk Line

## Steel Tops

Metal cutting equipment (Used for Field Cutting Filler Panels to Length)

## Laminate Tops

Metal cutting equipment (Used for Field Cutting Filler Panels to Length)

and

Laminate cutting equipment (Used for Field Cutting Filler Panels to Length)

## NOTE:

**Cabinets may become slightly mis aligned due to SHIPPING vibration. Before installing cabinets check cabinet to insure they are properly flush and square to avoid any installation issue. If you have an issue, contact your supplier before installing. Please note that the Unit Ventilator should be installed level and square prior to installing cabinetry.**

## **Field Cutting Equipment Recommended**

### **Steel Parts:**

Table Saw with a Carbide Blade. (Recommended)

Table saw will serve as your best advantage

You can set a back gauge and guarantee a straight cut while supporting your part. Table saw will also give you stability when you're cutting the steel parts.

Steel Parts that may need to be field cut:

Back Wall Angle

Adapter Channel

Front Panel

Floor Angle

### **Laminate Parts:**

Table Saw with a Panel Blade. (Recommended)

Table saw will serve as your best advantage

You can set a back gauge and guarantee a straight cut.

Table saw will also give you stability when you're cutting the laminate top.

Laminate Parts may need to be field cut:

Laminate Top

### **NOTES:**

Before cutting you must protect the finish by clamping a protective finish to the part that will face the table saw to prevent metal filings which could damage the finish.

Only qualified installers with the proper equipment should field cut parts to insure burr free and chip free parts.

Practice on scrap before attempting to cut finished parts.

# Table of Contents

- General Information
- Cabinet Hardware Packs
- Cabinet to Unit Ventilator Installation
- Cabinet-to-Cabinet Installation
- Cabinet to Filler Panel Installation
- Cabinet to Corner Installation
- End Panel Installation
- Utility Compartment Installation

# CABINET HARDWARE- Laminate Top

<b>Hardware for Laminate Top Cabinets</b>			<b>PAK# 2</b>
Qty	Part#	Description	Used For
2	025-A	Self Drilling #8 x 3/4" Screw w/ Washer Head	Secure Laminate Top to Wall Angle
2	173	1/4" x 20 - 3/4" Phillip Truss Head MS	Secure Unit Vent. to Cabinet
2	172	1/4" x 20 Serrated Nut	Secure Unit Vent. to Cabinet
4	175	1/4 x 20 - 1 1/4" Phillips Truss Head Screws MS	Secure Unit Vent., Cabinet to Cabinet
4	185	3/16" Allen Key - 1/4 x 20 Joint Connector Nut	Secure Cabinet to Cabinet
8	152	.375" Plastic Black Hole Plugs	Plug Hole for Internal Side
2	015	1/4 x 3/4" Phillips Truss Head "Type B" Screws	Secure Front Kick Plate to Base
1	055	Lower Back Wall Brace Set	Secure Base to Wall
4	060	2" Leg Leveler	Cabinet Leg Base Support
<b>Hardware for Filler Panel with Laminate Top</b>			<b>Pak # 2A</b>
Qty	Part#	Description	Used For
4	005	#6 x 1/2" Counter Sunk Self Drilling Screw	Secure Front Filler Trim to Front Panel
4	012	1/4 x- 1-1/4" Phillips Truss Head "Type AB" Screws	Secure Filler Adaptor Channel Top to Side Cabinet
3	015	1/4 x 3/4" Phillips Truss Head "Type B" Screws	Secure Filler Front Panel to Floor Angle
6	025A	#8 x 1" Phillips Washer Head Wood Screw	Secure Filler Adaptor Channel to Laminate Filler Top
6	030	.225 X .75 Steel Washer	Secure Filler Adaptor Channel to Laminate Filler Top
<b>Hardware for Inside Corner with Laminate Top</b>			<b>Pak # 2B</b>
Qty	Part#	Description	Used For
2	025	Self Drilling #8 x 3/4" Screw w/ Washer Head	Secure Corner Laminate Top to Wall Angle
4	015	1/4 x 3/4" Phillips Truss Head "Type B" Screws	Secure Corner Adaptor Channel to Laminate Filler Top
4	012	1/4 x- 1-1/4" Phillips Truss Head "Type AB" Screws	Secure Corner Top to Cabinet
6	025A	#8 x 1" Phillips Washer Head Wood Screw	Secure Corner Adaptor Channel to Laminate Corner Top
6	030	.225 X .75 Steel Washer	Secure Corner Adaptor Channel to Laminate Corner Top
<b>Hardware for End Panel with Laminate Top</b>			<b>Pak # 2C</b>
Qty	Part#	Description	Used For
4	012	1/4 x- 1-1/4" Phillips Truss Head "Type B" Screws	Secure Cabinet to End Panel
2	015	1/4 x 3/4" Phillips Truss Head "Type B" Screws	Secure Side Kick Plates To Base
<b>Hardware for Utility Compartment - STEEL TOP ONLY</b>			<b>Pak # 2D</b>
Qty	Part#	Description	Used For
4	005	Self Drilling TEK #6 Counter Sunk Screws	Secure Back Wall Angle to Top Panel
4	012	1/4 x- 1-1/4" Phillips Truss Head "Type AB" Screws	Secure Utility Compartment Top to Cabinet
2	015	1/4 x 3/4" Phillips Truss Head "Type B" Screws	Secure Front Kick Plate to Base
4	172	1/4 x 3/4" Phillips Truss Head Screws	Secure Unit Vent. to Cabinet
4	173	1/4" x 20 Serrated Nuts	Secure Unit Vent. to Cabinet
4	060	2" Leg Leveler	Cabinet Leg Base Support

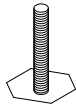

Part #060  
2" Leveling Leg



Part #152  
Black Plastic Hole Plug

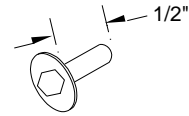

Part #185  
3/16" Allen 1/4 x 20  
Joint Connector Nut



Part #005  
#6 X 1/2" Self  
Drilling Screws

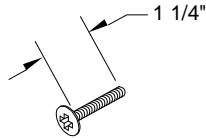

Part #175  
1/4" x 20 - 1 1/4"  
Phillips Truss Bolt

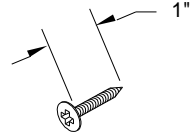

Part #025  
#8 x 1" Self Drilling  
Wood Screw  
(Laminate Top Only)

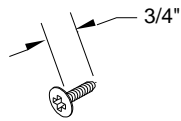

Part #015  
1/4" X 3/4" Phillips  
Truss Head "B" Screws

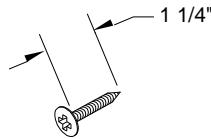

Part #012  
1/4" X 1 1/4" Phillips  
Truss Sheet Metal Screws

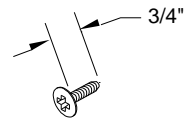

Part #173  
1/4" X 20 - 3/4" Phillips  
Truss Head M.S.



Part #172  
1/4 x 20 Serrated Nut

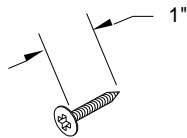

Part #025-A  
#8 x 3/4" Self Drilling  
Wood Screw  
(Laminate Top Only)



Part #030  
1/4" Washer  
(Laminate Top Only)

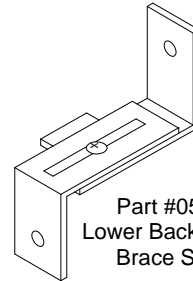

Part #055  
Lower Back Wall  
Brace Set

# Unit Ventilator to Laminate Top Cabinet

## Unit Ventilator to Laminate Top Cabinet

Note: Laminate Top Pre-Assemble at Factory

- Unpack Cabinet. Be careful when using sharp edges not to damage finish.
- Remove all parts and protective shipping wrapper. You may want to keep protective wrapper to use over equipment to protect finished installation.
- (A) Measure the height of the unit ventilator from the floor to the finished top.
- (B) Install (4) #060 Leveling Legs to the bottom base of the cabinet. Adjust leveling legs thru the cabinet base using a slotted screw driver to match unit ventilator height.
- (C) Install (1) #055 Lower Back Wall Brace to the rear lower back of the cabinet opposite unit ventilator.
- (D) Strike a line 1- 1/16" below Unit Ventilator and install Wall Angle level and to the wall.
- (E) Slide the cabinet back above the Wall Angle until the front of the cabinet is flush with the unit ventilator. Use leveling legs to level top and front of cabinet with unit ventilator if needed. Top, Front and Side of cabinet must be flush with unit ventilator prior to fastening.
- (F) Make sure the cabinet is level and flush to the unit ventilator. Remove front panel of Unit Ventilator and look for holes in the unit ventilator side frame that line up with holes in the side of the new cabinet. If there are none, drill 2- holes from the cabinet end panel into the frame of the unit ventilator. **Make sure you have clearance for the drill bit before drilling.**
- (G) Using (2) #0172 nuts & (2) #175 truss head machine screw, insert screw through the cabinet side panel into Unit Ventilator. Join screw with serrated nut on unit ventilator side and tighten. Make sure unit is flush on the top and front before tightening. **Note:** Other fastening may be needed.

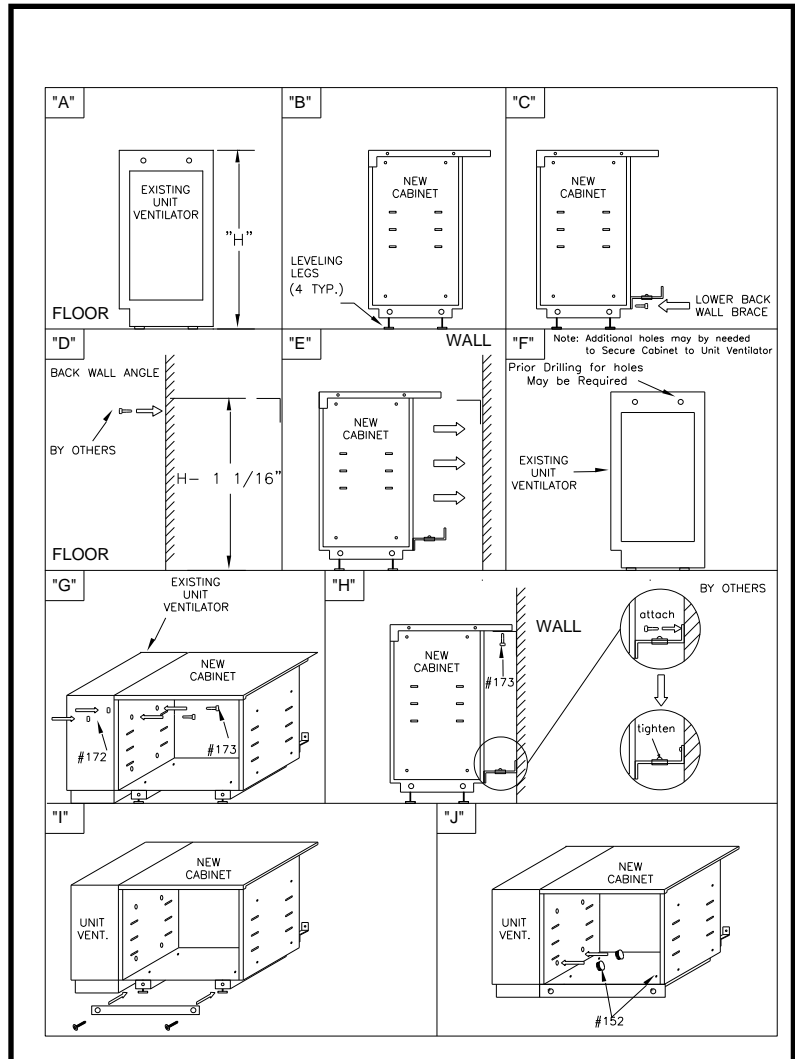

- (H) Using #025-A wood screw, secure the screw through the back wall angle into the laminate top. Fasten #055 lower back brace assembly to the wall. Adjust unit brace for correct depth and tighten prior to tightening'
- (I) Install front skirt using (2) #015 truss head "Type B" screws to bottom base. Adjust height to hide floor levelers.
- (J) Insert #0152 Black Plastic Hole Plugs to fill un used holes.

**\*\*NOTE:** Do not use hardware to pull cabinet and unit ventilator together

# Laminate Top Cabinet to Laminate Top Cabinet

## Laminate Top Cabinet to Laminate Top Cabinet

Note: Laminate Top Pre-Assemble at Factory

- Unpack Cabinet. Be careful when using sharp edges not to damage finish.
- Remove all parts and protective shipping wrapper. You may want to keep protective wrapper to use over equipment to protect finished installation.
- (A) Measure the height of the existing cabinet from the floor to the finished top.
- (B) Install (4) #060 Leveling Legs to the bottom base of the new cabinet. Adjust leveling legs on the cabinet to match existing cabinet height.
- (C) Install (1) #055 Lower Back Wall Brace to the rear lower back of the cabinet opposite existing cabinet.
- (D) Strike a line 1 1/16" below existing cabinet and install Back Wall Angle level and to the wall.
- (E) Insert laminate splice strip into alignment groove in side of laminate top. Slide the cabinet back on top of the Back Wall Angle until the front of the cabinet is flush with the existing cabinet. Line up laminate splice strip with groove in the existing cabinet and push cabinets together until there is no gap. Prior to fastening use leveling legs to level top and front of cabinet to existing cabinet if needed.
- (F) Using (4)#185 Joint Connectors & (4)#175 truss head machine screw, insert screw through hole in cabinet side panel. Make sure cabinets are flush on Top, Front and Side before tightening.
- (G) Fasten #055 lower back brace assembly to the wall. Adjust unit depth and tighten
- (H) Using #025-A wood screw, secure the screw through the back wall angle into the laminate top. Install front skirt using (2) #015 truss head "Type B" screws to bottom base. Adjust height to hide floor levelers.

\*\*NOTE: Do not use hardware to pull existing cabinet and new cabinet together

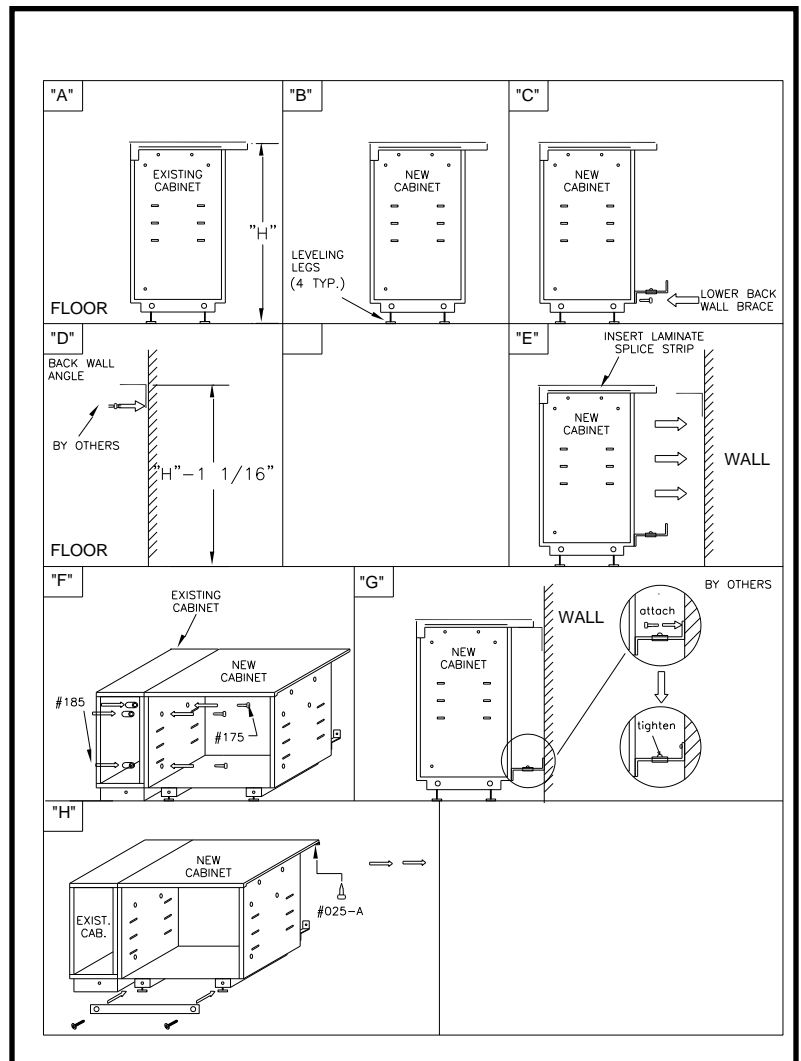



# Laminate Top Cabinet to Laminate Top Filler

## Laminate Top Cabinet to Laminate Top Filler Section to Wall

Included with Laminate Top filler sections: 1-Back Wall Angle, 1-Side top wall adapter angles, 1-Side wall angles, 1-Laminate Top, 1-Front Panel, 1-Floor angle and 1-Adapter Channel.

- Unpack Filler Section. Be careful when using sharp edges not to damage the finish.
- Remove all parts and protective shipping wrapper. You may want to keep protective wrapper to use over equipment to protect finished installation.
- (A) Determine the distance (A) between the end of the cabinet to the wall. Measure the height (A-1) of the existing cabinet from the floor to the finished top of existing cabinet. If filler section needs to be FIELD cut to size, follow step (B). If not, continue on to step (C).
- (B) Cut Back Wall Angle, Laminate Top and the Adapter Channel to "A" Dimension. This is the distance between the end of the cabinet to the wall. When cutting the adapter channel, be sure to cut the side that will be facing the wall. Cut Front Panel and Floor angle 1/4" less than the "A" Dimension. Use proper cutting equipment to insure laminate from chipping.
- (C) Strike a line 1/16" below the top of the existing cabinet and install Back Wall Angle level and flush to the wall. Make sure the back wall Angle is level and flush to existing cabinet (fastener by others).
- (D) Using (6) #025-A screws & (6) #030 washers, secure adapter channel and sidewall adapter angle (Right side shown) to the laminate top. Install (1) Laminate splice strip in groove on filler laminate top side facing existing cabinet.
- (E) Line up the mounting holes on the laminate adaptor channel against the holes in the cabinet side panel. Install laminate top on back Wall Angle and flush against cabinet top. If not flush and level adjust Back Wall Angle until top is flush and level.
- (F) Line up the holes in the existing cabinet with the holes in the adaptor panel. Insert (2) # 012 screws through the inner side top holes of the existing cabinet to the side of the adapter channel laminate top and tighten. Make sure the side top panel is flush and level and insert (2) fasteners through sidewall adapter angle in to the wall (Fasteners by others). Level prior to tightening all fasteners.
- (G) Align floor angle to existing cabinet front skirt. Fasten to floor through holes in bottom side of angle (Fasteners by other).
- (H) Slide (1) sidewall trim angle over the cut front panel.
- (I) With the sidewall trim angle in place, insert the bottom of the steel front panel behind the floor angle.
- (J) Line up front steel panel with top steel panel slots in the adapter channel. Using (3) #015 fasteners, lift up front panel into top panel adaptor channel and fasten front panel into place at the floor angle.
- (K) Slide front side trim angle tight against wall and insert (3) #005 Tek screws through counter sunk holes provided in side trim angle.
- Insert (4) #152 Hole plugs through internal side cabinet (Supplied in existing cabinet hardware).

\*\*NOTE: Do not use hardware to pull existing cabinet and new filler section together.

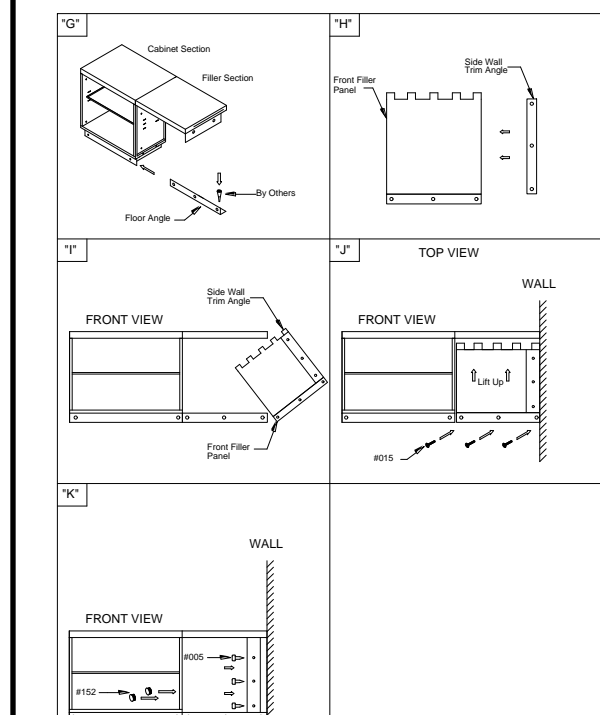
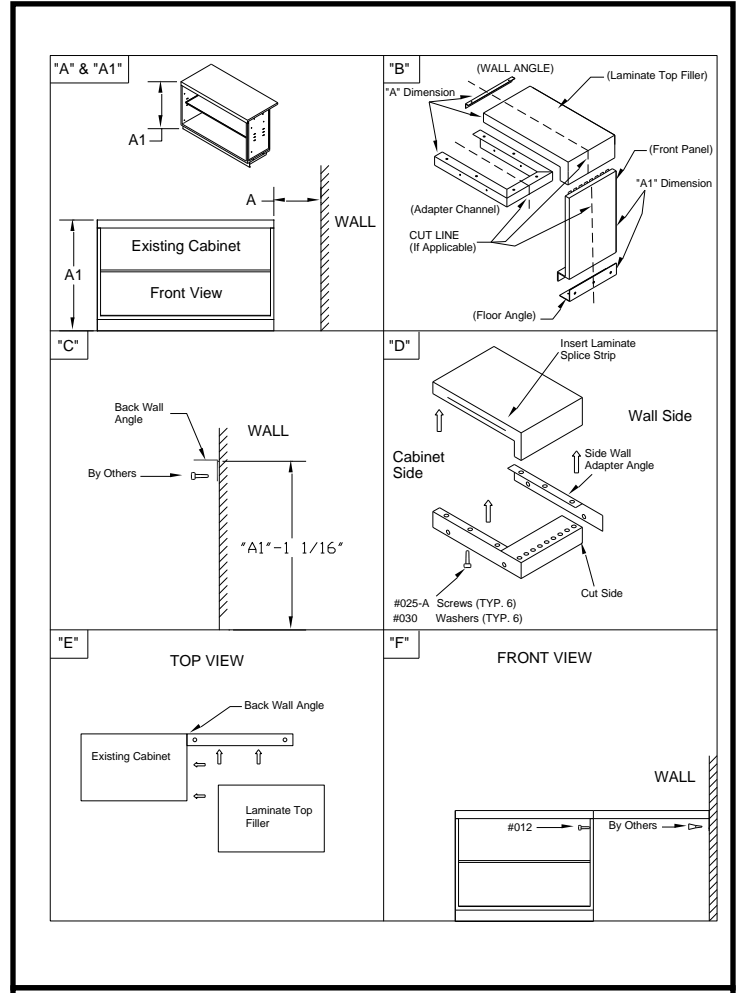

# Laminate Top Cabinet to Laminate Top Corner

## Laminate Cabinet to Laminate Top Corner

Note: Prior to installing, review room layout. For best installation, install corner prior to installing cabinets or accessories. Each corner side is design to be installed against cabinets. Corner can be installed against filler sections. **Corner cannot be cut or modified.**

- Unpack Laminate Top Corner. Be careful when using sharp edges not to damage the finish.
- Remove all parts and protective shipping wrapper. You may want to keep protective wrapper to use over equipment to protect finished installation.
- (A) Measure the height of the existing cabinet from the floor to the finished front top. Strike a line 1 1/16" below existing cabinet and install (2) Back Wall Angle to the wall. Make sure the Back Wall Angle is level to existing cabinet Back Wall Angle.
- (B) Install (2) laminate splice strips in side of corner laminate top.
- (C) Position laminate top corner on top of Back Wall Angle. Make sure the Corner top panel is level and flush.
- (D) Slide cabinet against laminate top corner making sure laminate splice strips are fully inserted in the side of the new cabinet laminate top and concealed. Make sure the Corner top panel is level and flush with the top of the cabinet. Adjust leveling leg of the new cabinet to insure holes in the laminate top corner adapter channel line up with the holes in the side of the cabinet. Insert (2) # 012 fasteners through the inside top holes of the cabinet side into the side of the adapter channel of the laminate top corner.
- (E) After one side of the cabinet is level and tighten, proceed to install the cabinet to the opposite side. Follow (D). The front corner of both cabinets must join together. If not, check to make sure cabinets are level.
- (F) Insert (6) #152 Painted Hole plugs through internal side cabinet (Supplied in cabinet hardware).

\*\*NOTE: Do not use hardware to pull existing cabinet and new corner section together

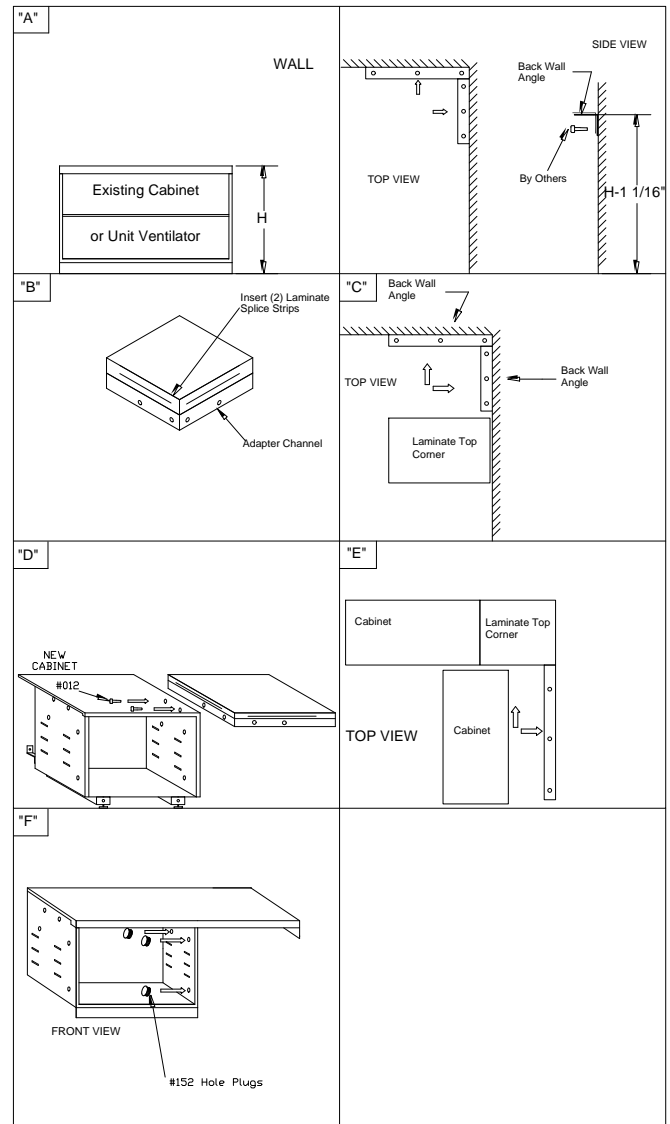

# Laminate Top Cabinet to End Panel

## Laminate Top Cabinet to End Panel

- Unpack End Panel. Be careful when using sharp edges not to damage the finish.
- Remove all parts and protective shipping wrapper. You may want to keep protective wrapper to use over equipment to protect finished installation.
- (A) Line up end panel to side of cabinet.
- (B) Insert (4) #012 screws through the hole on the inside of the cabinet side. Fasten screws into end panel holes. Make sure end panel is flush with all sides of the cabinet and tighten.

**\*\*NOTE:** Do not use hardware to pull existing cabinet

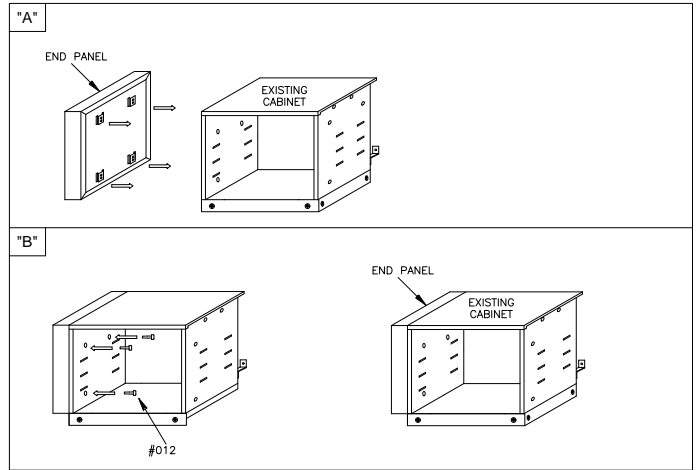

# Steel Top Utility Compartment

## Steel Top Utility Compartment

**Note:** Utility Compartments cannot be field modified. Utility compartments must have equipment installed on both sides.

- Unpack Utility panel. Be careful when using sharp edges not to damage the finish.
- Remove all parts and protective shipping box. You may want to keep protective box to use over equipment to protect finished installation.
- (A) Measure the height of the existing cabinet or unit ventilator from the floor to the finished front top "H". Install (4) #060 Leg Levelers & remove front panel.
- (B) Strike a line 1/16" above existing unit ventilator ("H" Dimension) and install Back Wall F-Channel to the wall. Make sure the F-Channel is level and flush.
- (C) **Installation of Utility Compartment to Unit Ventilator**

Prior to installing utility compartment, check to see if holes in the unit ventilator side frame line up with the holes in the utility compartment. If they do, line up utility compartment flush and level with the side of the unit ventilator. Identify the location where the holes need to be drilled. Make sure you do not drill into wires or components in the unit ventilator. When this is complete, slide utility compartment into Back Wall F-Channel lining up the front edge with existing equipment.

- (D) Align holes in the side of the top utility panel. Insert (2) #173 1/4" x 20-3/4" machine screws thru unit ventilator holes & tighten using 2-#173 1/4" x 20 serrated nuts. Adjust back wall F-Channel if needed to level with existing equipment. Make sure equipment on both sides are level and flush before tightening.
- (D-1) **Installation of Utility Compartment to Existing Cabinet**

Slide top utility panel into Back Wall F-Channel. Line up holes in the utility panel with the two top holes in the cabinet inner end panel. Insert (2) #112 1/4" X 1 1/4" sheet metal screws through the top holes in the inner end panel to the holes in the utility compartment top panel. Adjust back wall F-Channel if needed to level with existing equipment. Make sure equipment on both sides are level and flush before tightening

- (E) Install removable front panel.
- (F) Fasten (3) #005 Tek screws through the counter sunk holes in the F-Channel. This will secure unit in place. Using (2) #015 fasteners install front kick plate & adjust to hide leveling legs.

\*\*NOTE: Do not use hardware to pull existing cabinet and new filler section together

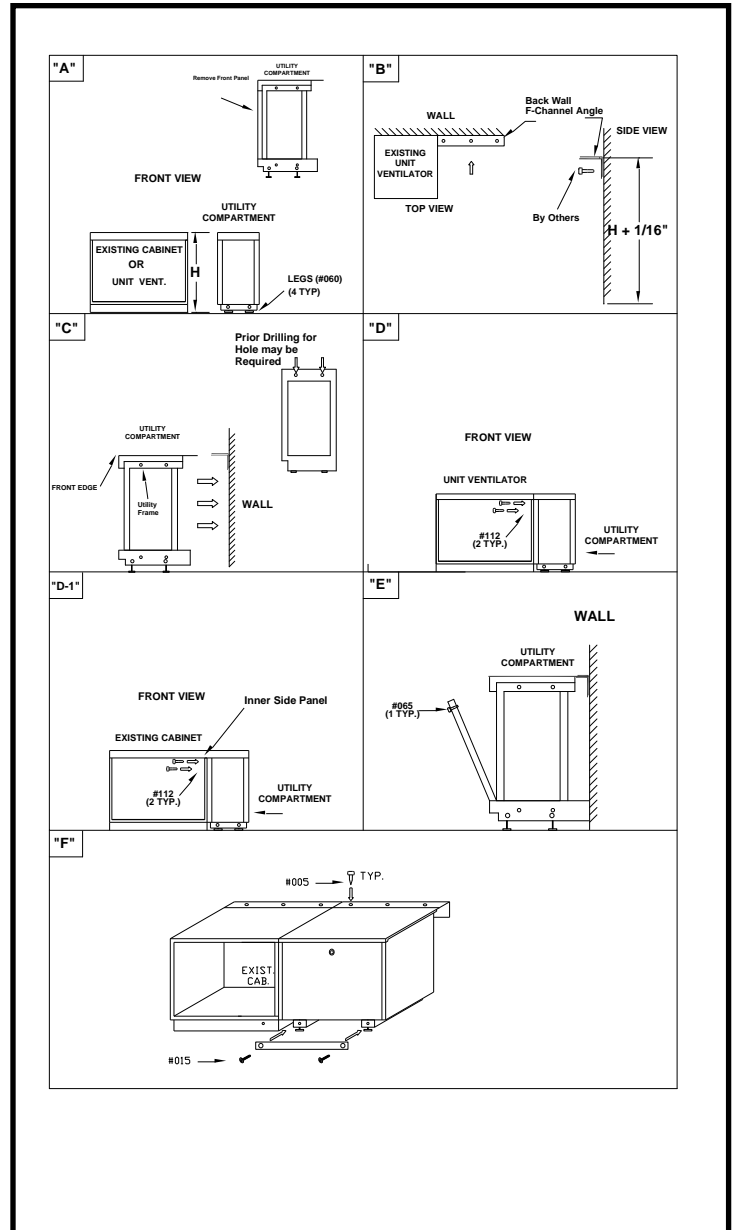

- **NOTE: Prior drilling for holes in unit ventilator side frame may be required.** Remove access panel on Unit Ventilator. Line up two top holes in the side end panel of new cabinet with the side frame of the unit ventilator. **(If Required)** Drill two 3/8" holes from the inside of the new cabinet side holes into the side frame of unit ventilator. **Make sure you have clearance for the drill bit before drilling. Additional fastening may be required.**