

STORAGE CABINET INSTALLATIONS MANUAL

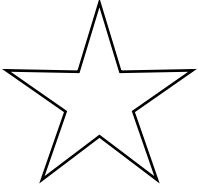

Model-Steel Top

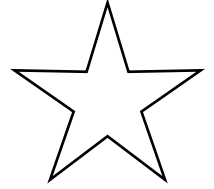

**Durable – Interchangeable
Easy to Install**

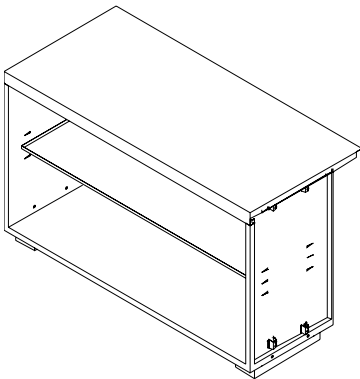

Cabinet - no doors
Steel Top

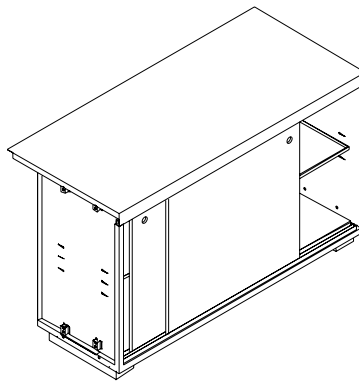

Cabinet - with doors
Steel Top

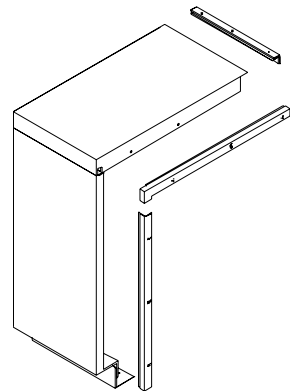

Filler Panel
Steel Top

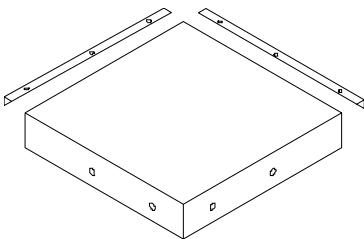

Corner Section
Steel Top

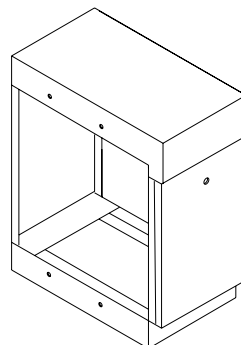

Utility Compartment

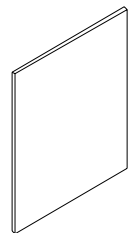

End Panel

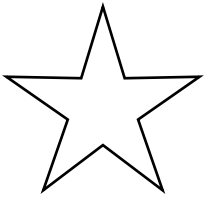

Before you Unpack this Equipment

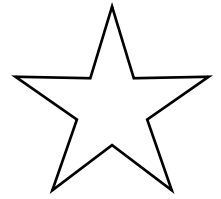

- Check ALL cartons for possible freight damages. If damaged, do not continue to open. Report all damages to the freight carrier and your sales representative.
- Count to make sure the number of boxes matches the packing slip. If they do not, check your Bill of Lading to make sure you received all your equipment.

General Information

HVAC CUSTOM ENCLOSURE CO., LLC provides the industry with high quality cabinetry that is easy to install. Read your instruction manual prior to installing your equipment. Familiarize yourself with the layout of the room, size and arrangement of the cabinets. This manual will provide you with information to properly install this equipment. Cabinets come with tops pre-assembled. Cabinets are available in two, three, four and five feet lengths. Each standard cabinet comes with one adjustable shelf, front and side floor skirts, back wall brace, back F-channel and hardware pack. Fasteners required to secure equipment to floors and walls **ARE SUPPLIED BY OTHERS.**

Before Installing:

You will need the following tools.
(Additional tools may be needed for fastening to the wall and floor)

Adjustable Drill
Long Phillips Head Bit to fit in Drill (Magnetic Bit Recommended)
Tape Measure
Contractor Level
Marking Device

Steel Tops

Metal cutting equipment (Used for Field Cutting Filler Panels to Length)

or

Laminate Tops

Metal cutting equipment (Used for Field Cutting Front Steel Filler Panels to Length)

and

Laminate cutting equipment (Used for Field Cutting Filler Panels to Length)

Table of Contents

- General Information
- Cabinet Hardware Packs
- Cabinet to Unit Ventilator Installation
- Cabinet-to-Cabinet Installation
- Cabinet to Filler Panel Installation
- End Panel Installation
- Cabinet to Corner Installation
- Utility Compartment Installation

CABINET HARDWARE – Steel Top

Hardware for Cabinets with Steel Tops			PAK#1
Qty	Part#	Description	Used For
6	005	Self Drilling TEK #6 Counter Sink Screws	Secure Top to F-Channel
8	035	1/4 x 20 Tinnerman J-Clips	Secure Unit Vent., Cabinet to Cabinet
8	040	5/8" OD x .260" ID Plastic Spacers	Secure Unit Vent., Cabinet to Cabinet
8	045	1/4 x 20 - 1 1/4" Phillips Truss Head Screws MS	Secure Unit Vent., Cabinet to Cabinet
8	050	7/8" Hole Plugs	Plug Hole for Internal Side
1	055	Lower Back Wall Brace Set	Secure Bottom of Cabinet to Wall
4	060	1 1/2" Leg Leveler	Leg Support
6	015	1/4 x 3/4" Phillips Truss Head "B" Screws	Secure Front and Side Skirt to Leg Base
Hardware for Filler Sections with Steel Tops			PAK#1A
Qty	Part#	Description	Used For
20	005	Self Drilling TEK #6 Counter Sink Screws	Secure Top/Side/Front to F-Channel
4	010	1/4 x 1-1/4" Phillips Truss Head "B" Screws	Secure Cabinet to Top Filler Section
3	015	1/4 x 3/4" Phillips Truss Head "B" Screws	Secure Front Panel to Floor Angle
Hardware for Inside Corners with Steel Tops			PAK#1B
Qty	Part#	Description	Used For
8	005	Self Drilling TEK #6 Counter Sink Screws	Secure Corner Top to F-Channel
4	010	1/4 x 1-1/4" Phillips Truss Head "B" Screws	Secure Cabinet to Top Corner Section
Hardware for End Panels			PAK#1C
Qty	Part#	Description	Used For
4	010	1/4 x 1-1/4" Phillips Truss Head "B" Screws	Secure Cabinet to End Panel
4	040	5/8" OD x .260" ID Plastic Spacers	Secure Cabinet to End Panel
Hardware for Utility Compartment with Steel Tops			PAK#1D
Qty	Part#	Description	Used For
10	005	Self Drilling TEK #6 Counter Sink Screws	Secure Top F-Channel/Divider Panel
4	040	5/8" OD x .260" ID Plastic Spacers	Secure Utility to Cabinet/U.V.
8	010	1/4 x 1-1/4" Phillips Truss Head "B" Screws	Secure Utility End Panel/Filler Section
8	015	1/4 x 3/4" Phillips Truss Head "B" Screws	Secure Front Rail to Base/Skirts to Base
4	045	1/4 x 20 - 1 1/4" Phillips Truss Head Screws MS	Secure Utility to Cabinet/U.V.
4	060	1 1/2" Leg Leveler	Leg Support
1	065	1/4 x 20 - 3/4" Hex Truss Head Screws MS	Secure Front Panel in Place

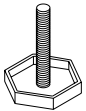

Part #060
1 1/2" Leveling Leg



Part #050
7/8" Hole Plug



Part #040
5/8" OD X 0.260 ID
Plastic Spacer



Part #035
1/4" X 20
Tinnerman J-Clip



Part #005
#6 X 1/2" Self
Drilling Screws



Part #070
1/4" Fender Washer

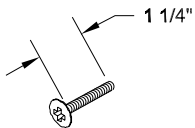

Part #045
1/4" X 20-1 1/4" Phillips
Truss Head Screws

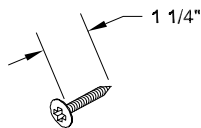

Part #010
1/4" X 1 1/4" Phillips
Truss Head "B" Screws

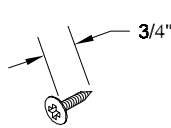

Part #015
1/4" X 3/4" Phillips
Truss Head "B" Screws

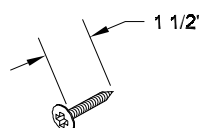

Part #065
1/4" x 1 1/2" Self Drilling
Phillips Head Screws

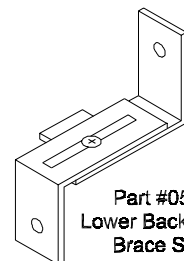

Part #055
Lower Back Wall
Brace Set

Unit Ventilator to Steel Top Cabinet

- Unpack Cabinet. Be careful when using sharp objects not to damage the finish.
- Remove all parts and protective shipping wrapper. You may want to keep protective wrapper to use over equipment to protect finished installation.
- **(A)** Measure the height of the unit ventilator from the floor to the finished top.
- **(B)** Install (4) #060 Leveling Legs to the bottom base of the cabinet. Adjust leveling legs on the cabinet to match unit ventilator height.
- **(C)** Install (1) #055 Lower Back Wall Brace to the rear lower back of the cabinet opposite unit ventilator.
- **(D)** Strike a line 1/16" above (H-Dimension). Install F-Channel level and flush to the wall.
- **(E)** Install (2) #035 J-Clips to the top side mounting angle on the unit ventilator.
- **(F)** Slide cabinet back into the F-Channel until the front of the cabinet is flush with the unit ventilator. Use leveling legs to level top and front of cabinet with unit ventilator if needed. Top, Front and Side of cabinet must be flush with unit ventilator prior to fastening.
- **(G)** Using (2) #040 plastic spacers, (2) #045 truss head machine screw, insert screw through spacer hole into the cabinet top side panel. Join screw with #035 J-Clip on unit ventilator and tighten. Make sure unit is flush and level on the top and front before tightening.
- **(H)** Fasten #055 lower back brace assembly to the wall. Adjust unit brace for correct depth and tighten.
- **(I)** Fasten (6) #005 Tek screws through the countersunk holes in the F-Channel. This will secure unit in place. Install front skirt using (2) #065 truss head "Type B" screws to bottom base. Adjust height to hide floor levelers. Install side skirts (Optional) using (2) #065 truss head "Type B" screws to bottom base
- **(J)** Insert (4) #050 Painted Hole plugs.

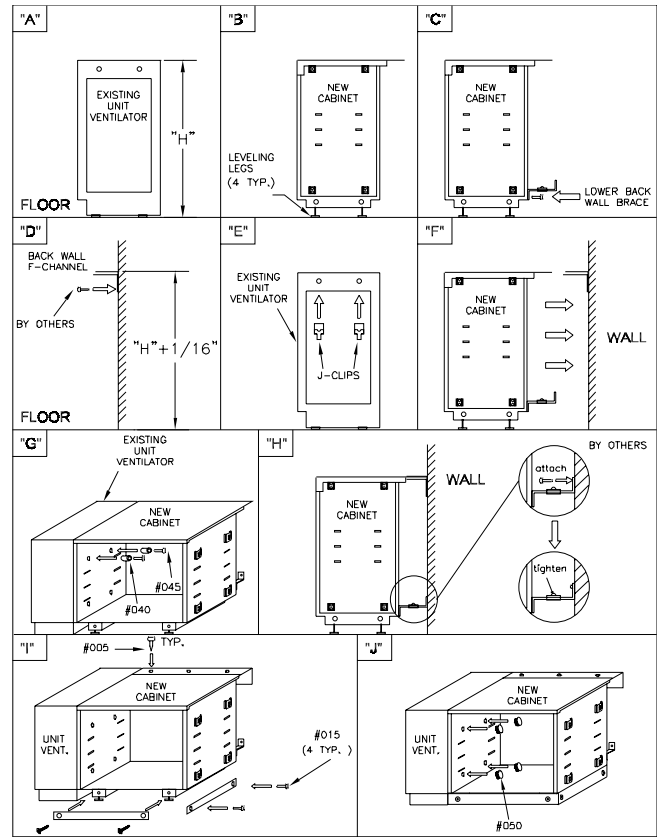

****NOTE:** Do not use hardware to pull cabinet and unit ventilator together

Steel Top Cabinet to Steel Top Cabinet

- Unpack Cabinet. Be careful when using sharp objects not to damage the finish.
- Remove all parts and protective shipping wrapper. You may want to keep protective wrapper to use over equipment to protect finished installation.
- **(A)** Measure the height of the existing cabinet from the finished floor to the finished front top.
- **(B)** Install (4) #060 Leveling Legs to the bottom base of the new cabinet. Adjust leveling legs on the cabinet to match existing cabinet height.
- **(C)** Install (1) #055 Lower Back Wall Brace to the rear lower back of the cabinet opposite existing cabinet.
- **(D)** Strike a line 1/16" above existing cabinet and install F-Channel to the wall. Make sure the F-Channel is level to existing cabinet F-Channel.
- **(E)** Install (4) #035 J-Clips to the external side of the existing cabinet.
- **(F)** Slide the cabinet back into the F-Channel until the front of the cabinet is flush with the existing cabinet. Use leveling legs to level top and front of cabinet to existing cabinet if needed. Top, Front and Side of cabinet must be flush with existing Top, Front and Side of new cabinet prior to fastening.
- **(G)** Using (4) #040 plastic spacers, (4) #045 truss head machine screws, insert screw through spacer hole into the cabinet top side panel. Join screw with (4) #035 J-Clips on external side of existing cabinet and tighten. Make sure cabinets are flush and level on the Top, Front and Side before tightening.
- **(H)** Fasten #055 lower back brace assembly to the wall. Adjust unit brace for correct depth and tighten.
- **(I)** Fasten (6) #005 Tek screws through the countersunk holes in the F-Channel. This will secure unit in place. Install front skirt using (2) #065 truss head "Type B" screws to bottom base. Adjust height to hide floor levelers. Install side skirts (Optional) using (2) #065 truss head "Type B" screws to bottom base
- **(J)** Insert (4) #050 Painted Hole plugs.

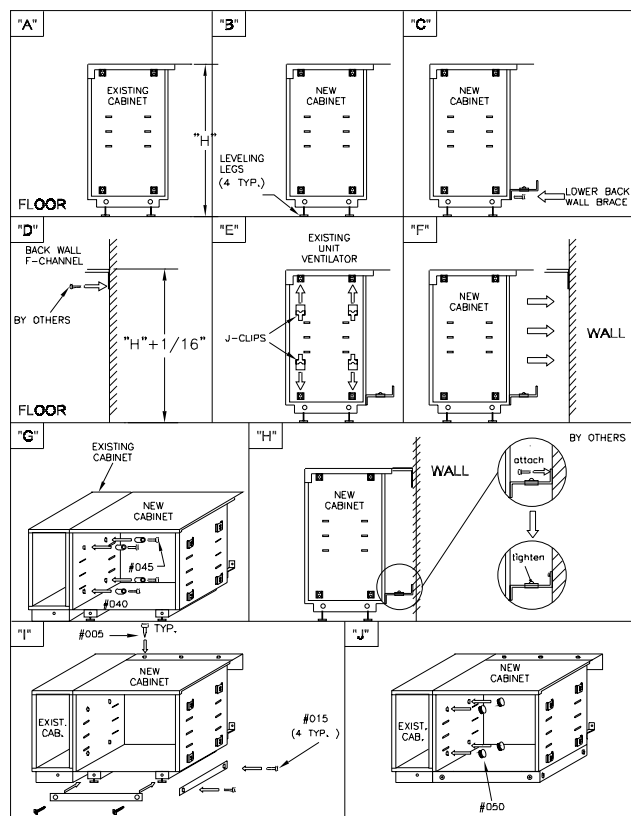

****NOTE:** Do not use hardware to pull existing cabinet and new cabinet together

Steel Top Cabinet to Steel Top Filler Panel to the Wall

Included with Steel top filler sections: 1-Back Wall F-Channel, 1-Set of side wall trim angles, 1-Set of top wall trim angles, 1-Steel Top, 1-Front Panel and 1-Floor angle.

- Unpack Filler Section. Be careful when using sharp objects not to damage the finish.
- Remove all parts and protective shipping wrapper. You may want to keep protective wrapper to use over equipment to protect finished installation.
- **(A)** Determine the distance between the end of the cabinet and the wall (A-Dimension). Measure the height of the existing cabinet from the floor to the finished front top of existing cabinet (A1-Dimension). If filler section needs to be cut to size, follow step (B). If not, continue on to step (C).
- **(B)** Cut Back Wall F-Channel, Floor Angle the distance between the end of the cabinet and the wall (A-Dimension). Cut Steel Top, Front Panel $1/4"$ less than (A-Dimension) the distance between the end of the cabinet and the wall.
- **(C)** Strike a line $1/16"$ above existing cabinet (A1-Dimension) and install F-Channel to the wall. Make sure the F-Channel is level and flush to existing cabinet F-Channel.
- **(D)** Slide the top wall trim angle onto the cut side of the steel top panel. Slide steel top filler panel into F-Channel until the front panel is lined up flush with the existing cabinet. Line up the mounting holes on the steel top filler panel against the holes in the side of the existing cabinet.
- **(E)** Make sure the top panel is level and flush with the cabinet. Insert (2) #010 fasteners through the inside top holes of the existing cabinet into the side of the steel top filler panel.
- **(F)** With the holes provided in the side of the filler top wall trim angle, fasten angle to the wall (Fasteners by others). Make sure side top panel is flush and level prior to tightening all fasteners. Install #005 Tek screws through the F-Channel and side wall trim angle securing the steel top in place.
- **(G)** Align floor angle to existing cabinet front skirt. Fasten to floor through holes in bottom side of floor angle (Fasteners by other).
- **(H)** Slide front sidewall trim angle over the cut front panel.
- **(I)** With the sidewall trim angle in place, insert the bottom of the steel front panel behind the floor angle.
- **(J)** Line up front steel panel with the aligning slot in the top steel panel. Using (3) #015 fasteners, lift up front panel into top panel and fasten front panel into place at the floor angle.
- **(K)** Slide front side trim angle tight against wall and insert (6) #050 Tek screws through countersunk holes provided in side trim angle.
- **(L)** Insert (4) #050 Painted Hole plugs through internal side cabinet (Supplied in existing cabinet hardware).

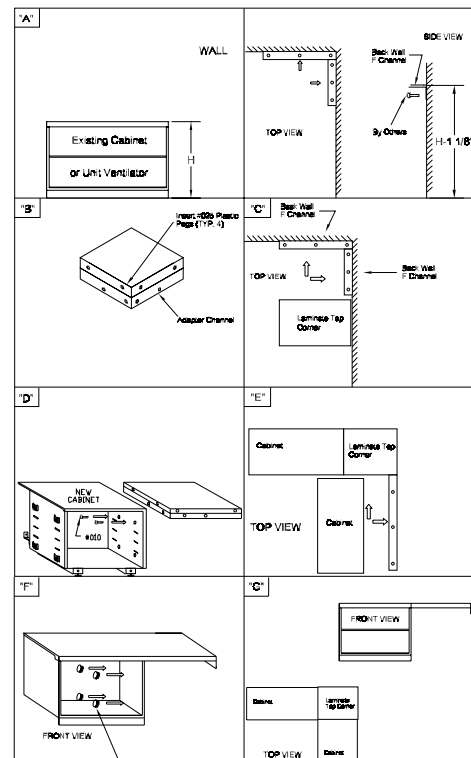
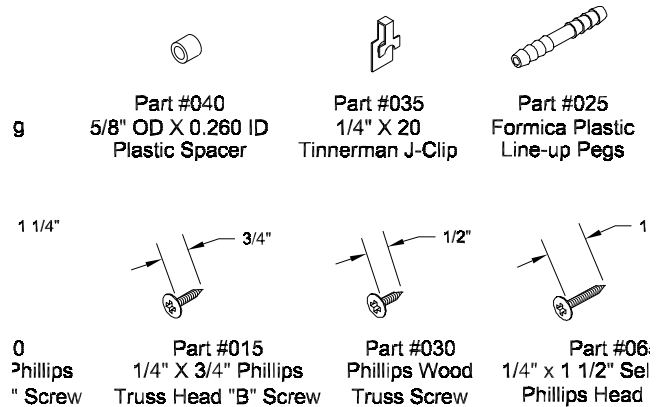

****NOTE:** Do not use hardware to pull existing cabinet and new filler section together

Steel Top Cabinet to Steel Top Corner

Note: Prior to installing, review room layout. For best installation, install corner prior to installing cabinets or accessories. Each corner side is design to be installed against cabinets. Corner can be installed against filler sections.

- Unpack Steel Top Corner. Be careful when using sharp objects not to damage the finish.
- Remove all parts and protective shipping wrapper. You may want to keep protective wrapper to use over equipment to protect finished installation.
- **(A)** Measure the height of the existing cabinet from the floor to the finished front top. Strike a line 1/16" above existing cabinet and install (2) Back Wall F-Channel to the wall. Make sure the F-Channel is level and flush to existing cabinet F-Channel.
- **(B)** Slide Steel top corner into F-Channel.
- **(C)** Make sure the Corner top panel is level and flush with the cabinet. Adjust leveling leg of cabinet to insure holes in the steel top corner line up with the holes in the cabinet. Insert (2) #010 fasteners through the top inside side panel of the cabinet into the side of the steel top corner.
- **(D)** Slide cabinet against steel top corner (follow installation instructions of cabinet). Make sure the Corner top panel is level and flush with the cabinet. Adjust leveling leg of the new cabinet to insure holes in the steel top corner line up with the holes in the new cabinet. Insert (2) #010 fasteners through the inside top holes of the cabinet into the side of the steel top corner.
- **(E)** Repeat the same procedure on the opposite side of the corner.
- **(F)** Once corners and cabinets are tightened, install (4) #005 Tek screw through the top back wall F-Channel countersunk holes.
- **(G)** Insert (4) #050 Painted Hole plugs through internal side cabinet (Supplied in cabinet hardware).

****NOTE:** Do not use hardware to pull existing cabinet and new corner section together

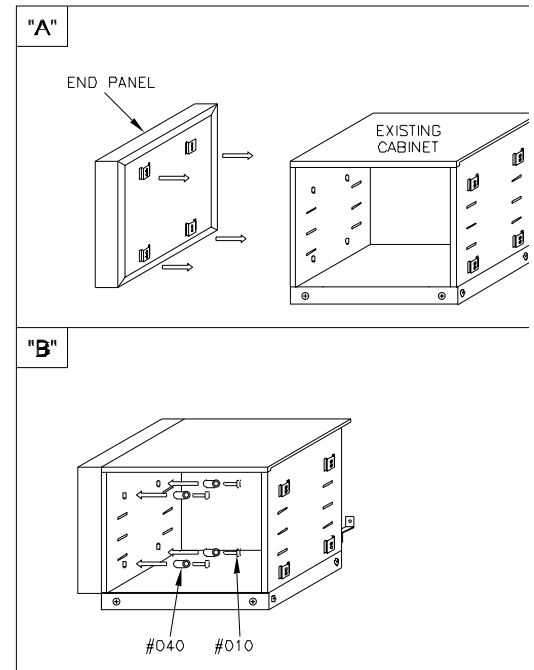

Steel Top Cabinet to End Panel

- Unpack End Panel. Be careful when using sharp objects not to damage the finish.
- Remove all parts and protective shipping wrapper. You may want to keep protective wrapper to use over equipment to protect finished installation.
- **(A)** Line up end panel to side of cabinet.
- **(B)** Insert (4) #010 screws through (4) #040 spacers into the cabinet side. Fasten screws into end panel holes. Make sure end panel is flush with all sides of the cabinet and tighten.
- Insert (4) #050 Painted Hole plugs through internal side cabinet (Supplied in existing cabinet hardware).

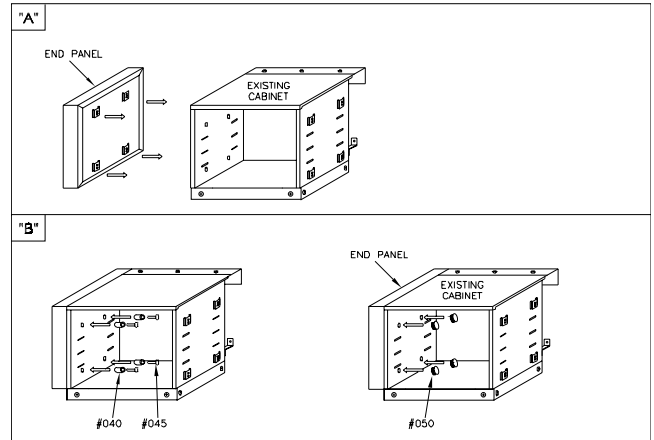

****NOTE:** Do not use hardware to pull existing cabinet together

Steel Top Utility Compartment

Note: Utility Compartment must have End Panels or fasten to other equipment.

Utility Compartment comes pre-assembled with hardware pak and Back Wall F-Channel.

- Unpack Utility Compartment. Be careful when using sharp objects not to damage the finish.
- **(A)** Install (4) #060 Leveling Legs
- **(B)** Strike a line 1/8" above existing Equipment and install F-Channel to the wall. Make sure the F-Channel is level to existing equipment. If installing against existing cabinet, install F-Channel flush with cabinet F-Channel. Use Leveling Legs for final adjustment.
- **(C) Utility Compartment to Unit Ventilator:** Insert (2) #035 J-Clips onto unit ventilator side frame.
- **(D)** Slide Utility Compartment onto F-Channel.
- **(E)** Insert (2) #045 screws through adapter channel into unit ventilator clips. Make sure top is level and flush on all sides before tightening. Adjust back F-Channel if need to level to existing equipment. Go on to Step (I).
- **(F) Utility Compartment to Existing Cabinet:** Insert (4) #035 Clips onto the side of the existing cabinet in (4) places.
- **(G)** Slide Utility Compartment onto F-Channel.
- **(H)** Insert (4) #045 screws through steel top into unit existing cabinet clips. Make sure top is level and flush on all sides before tightening. Adjust back F-Channel if need to level to existing equipment. Go on to Step (I).
- **(I)** Prior to installing front panel, make sure all equipment on either side is installed. When both sides of utility compartment equipment are installed, install front panel by inserting locator pins into bottom base rail. Push front panel into top and fasten using (1) #065 fastener.
- **(J)** Install front skirt using (2) #010 fasteners. Install side skirts if needed.

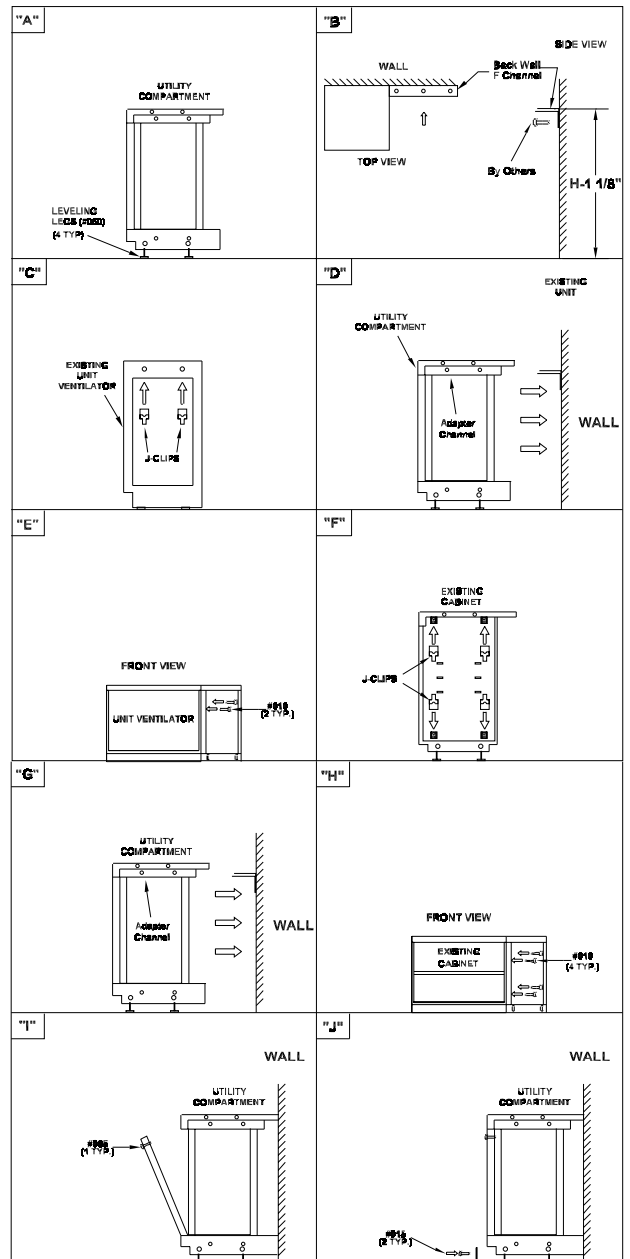

****NOTE:** Do not use hardware to pull cabinet together